

ULTRA-MAG

Flexible Magnetic Extrusions



Description

Custom designed extrusion and custom cut parts to fit your specifications. Standard and high energy strip. Magnetized with the correct pattern for your application, or not magnetized. Strip available with pressure sensitive adhesive backing.

Magnetic Properties of Ultra-Mag-Standard

Maximum Energy Product (BH _{max} x 10 ⁶)	.078
Residual Induction B _r (gauss)	.1850
Coercive Force H _c (oersteds)	.1500
Intrinsic Coercive Force H _{ci} (oersteds)	.2400

Physical Properties of Ultra-Mag

Specific Gravity	.3.7
Hardness	Shore D52
Ultimate Tensile Strength psi	.1000

Higher energy values available upon request.

Patterns of Magnetization

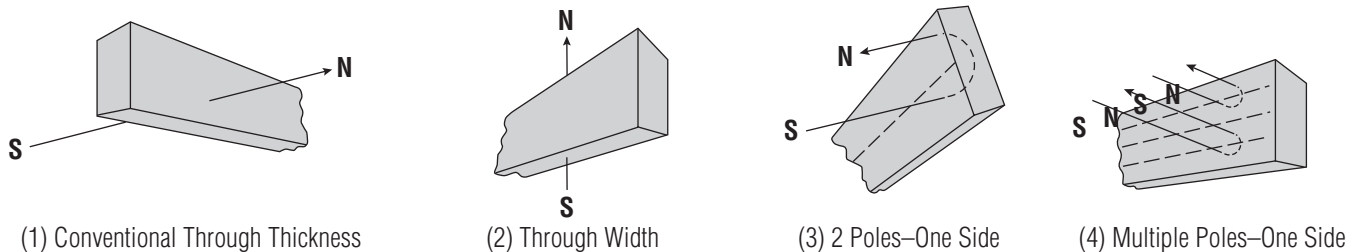

Typical Examples of Ultra-Mag Custom Made Shapes

Extruded:

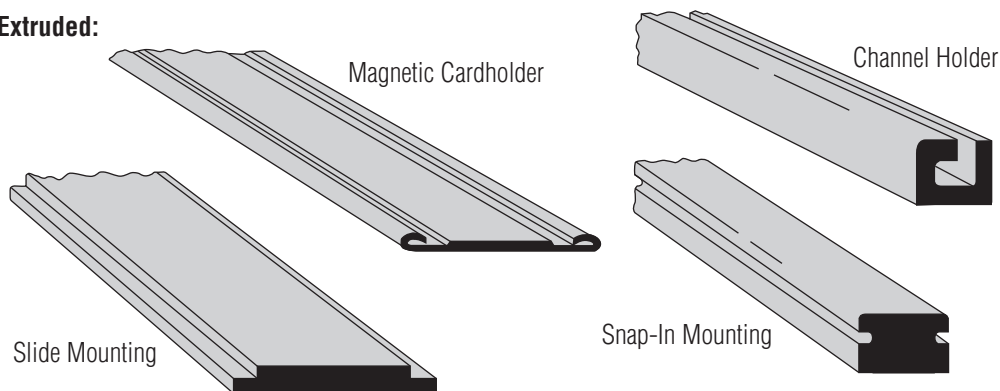

Stamped:

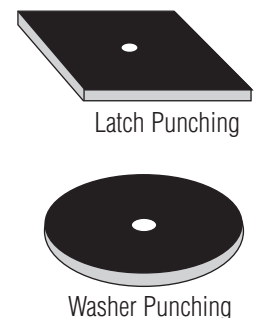

Call your Flexmag Industries Representative today.



107 Industry Road • Marietta, OH 45750
 800-543-4426 • 740-374-8024 • Fax: 740-374-5068
 www.Flexmag.com